

Design & Simulation of Ups Inverter with Pi Controller and Ann: A Review

Raja Soumya Swaroop Patra, Pankaj Kumar, Tapan Kumar Baral,
Md Riyajul Haque, Ishita Mohanty, Ankesh Agrawal

Department of Electrical and Electronics Engineering, Gandhi Institute For Technology (GIFT), Bhubaneswar

ABSTRACT: An uninterruptible power supply, also uninterruptible power source, UPS or battery/flywheel backup, is an electrical apparatus that provides emergency power to a load when the input power source or mains power fails. A UPS differs from an auxiliary or emergency power system or standby generator in that it will provide near-instantaneous protection from input power interruptions, by supplying energy stored in batteries, supercapacitors, or flywheels. The on-battery runtime of most uninterruptible power sources is relatively short (only a few minutes) but sufficient to start a standby power source or properly shut down the protected equipment. Uninterruptible power supplies (UPSes) are used to provide backup power to critical loads, where even a temporary power failure causes large economic losses. The UPSes are used in applications like computer installations, process control in chemical plants, and general communication systems. The function of UPS is to provide a high quality sinusoidal voltage and for this it needs to be controlled. Conventional controllers cannot provide the exact sinusoidal output with the nonlinear loads. The objective of this project is to control inverter output voltage by maintaining it as a high quality sinusoidal shaping in nature with low total harmonic distortion (THD) for UPS applications. This is to be accomplished by an artificial neural network Controller in closed loop further the performance of the UPS inverter with neural network controller is to be compared with PI controller.

KEY WORD: UPSes, Power failure, THD, UPS inverter, Neural Network, PI Controller, MATLAB

I. INTRODUCTION

The uninterruptible power supplies are emergency power sources for applications where a power failure for a small amount of time causes large disturbances. The neural network control of UPS inverters is capable of producing low total harmonic distortion. Since a PI controller is designed from linear system theory, the output voltage of UPS inverter with PI controller will get distortion for nonlinear loads. The neural network had an advantage of adaptability to all types of loads, reduces the total harmonic distortion of output voltage, and hence used for the control of output voltage in UPS inverter applications. The design, implementation and testing of closed loop control of PI based UPS inverter and an artificial neural network based UPS inverter has been carried out. With the help of Matlab/Simulink toolbox. An artificial neural network is trained with the samples for different load values obtained from a controller, with back propagation algorithm. The simulation results of closed loop control of PI based UPS inverter and an artificial neural network based UPS inverter had been studied.

1.1 OBJECTIVE: The objective of this project is to control inverter output voltage by maintaining it as a high quality sinusoidal shaping in nature with low total harmonic distortion (THD) for UPS applications. This is to be accomplished by an artificial neural network Controller in closed loop further the performance of the UPS inverter with neural network controller is to be compared with PI controller.

II. LITERATURE SURVEY

[1] According to P.D.Ziogas, Uninterruptible power supplies are emergency power sources, which have wide spread applications in critical equipments, such as computers, automated process controllers, and in hospital instruments. With the rapid growth in high-efficiency power converters, more and more electrical loads are non-linear and generate harmonics. It is big challenge for a UPS to maintain a high quality sinusoidal output voltage under non-linear loading condition. The high quality sinusoidal output voltage is usually achieved by employing a combination of pulse width modulation (PWM) scheme and a second order filter at the output of the inverter. A multiple feedback-loop control scheme can be utilized to achieve good dynamic response and low total harmonic distortion. The control scheme is based on sensing the current in the capacitor of the output filter, using it in an inner feedback loop.

[2] According J.E.Quaicoe, Uninterruptible power supply (UPS) systems are used to provide continuous and reliable electrical power to loads in times of unexpected power failure. By connecting the UPS inverters in

parallel, its capacity is expandable. Parallel operation of inverters is gaining importance, because it increases system efficiency, provides redundancy and modularity.

[3] According W.E.Brumsickle, In a typical UPS inverter there is a Pulse-Width Modulation (PWM) converter and a second-order LC output filter. The UPS Inverter voltage can be controlled by using PWM techniques. The Sinusoidal PWM technique is used in this work, in which the width of each pulse is varied in proportion to the amplitude of the sine wave, which results in sinusoidal output voltage with a low THD. In this paper we propose neural and neuro-fuzzy based controllers with offline training for UPS inverter applications. Simulation results show that the developed neural and neuro fuzzy controllers can achieve low THD under nonlinear loading condition and good dynamic response under transient loading condition when compared to without controller and with PI controller. Fuzzy logic and neural network technologies are in the process of fast evolution. The frontier of power electronics and motion control, which is already so complex and interdisciplinary, will be definitely extended far and wide by the AI techniques, and will provide a great challenge to the community of power electronic engineers.

III. CONVENTIONAL TOPOLOGIES OF UNINTERRUPTIBLE POWER SUPPLIES

3.1 INTRODUCTION

The industrial and commercial power committee of the IEEE defines an UPS as a system which is designed to provide power during all periods where in the normal or prime source of power is outside acceptable limits, without causing disruption of the flow of acceptable power to load. The historic function of the UPS was to provide backup power to critical loads to maintain the operation when the prime source of power fails. This chapter details the basic topologies of uninterruptible power supplies (UPSes), main parts of UPS system. It also explains the types of PWM inverters for UPS inverter applications.

3.2 MAIN PARTS OF UPSes

The block diagram of UPS is as shown in figure 3.1. There are two types UPS systems are available known as Static and Rotary. A solid state (static) UPS comprises of following units.

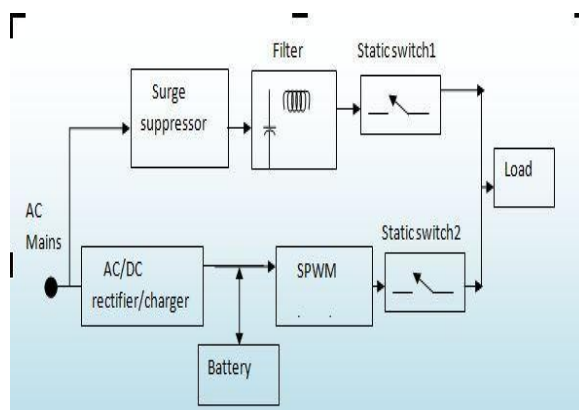

Fig 3.1: Block diagram of general UPS System

- Conversion and inversion circuitry: All the UPS systems include a rectifier or charger circuit to provide DC to charge the battery and an inverter circuit that converts the DC power stored in battery to AC power to operate the loads. The exact type, nature, size and quality of this circuitry depend on the type of UPS.
- Battery: Other than the conversion and inversion circuit, another one is battery, which holds the energy that is used by UPS to run the load. The size of the battery dictates the size of the UPS and it is also proportional to the amount of energy that stored in UPS and run time of UPS for a given load. All (in Volts), and their capacity (in Amp-hours or “Ah”).
- Status indicators: Most of the UPS systems come with variety of indicators to indicate the current status of the UPS. Visual indicators (usually LEDs) are used to indicate general status as well as problem conditions. Audible indicators, sometimes called as alarms, are used to indicate some problem conditions like power failure. Some of the typical status indicators are online, on battery, overload, Low battery, Load status, Battery status.

3.2 TYPES OF PWM INVERTERS

The pulse width modulated (PWM) inverters are generally used for UPSes to maintain the output voltage as constant and regulates the output as sinusoidal shape in nature. The PWM type inverters are having an advantages of exclusion of lower order harmonics in the output voltage along with the control capabilities of output voltage, the harmonics in the inverter output are being eliminated by PWM technique, the filter circuit requirements are minimized. PWM techniques are characterized by constant amplitude pulses. The width of these pulses is modulated to control the inverter output voltage and for the reduction of harmonic content.

The Different PWM techniques are

- Single pulse modulation
- Multiple pulse modulation
- Sinusoidal pulse modulation.

The output voltage of single pulse width modulated inverter is of only one pulse located symmetrically. The width of the pulse is varied to control the inverter output voltage. The output voltage of single pulse width modulated inverter is quasi-square in nature and the harmonic content is more, which is not suitable for UPS applications.

IV. CLOSED LOOP CONTROL OF UPS INVERTER WITH CONVENTIONAL CONTROLLER

4.1 INTRODUCTION

The core circuit of the UPS system is the inverter circuit, which is required for power conversion from dc (battery) to ac power. Inverter circuits can be broadly classified into two types,

- Voltage source inverters(VSI) and
- Current source inverters (CSI).

A voltage source inverter is one in which the dc source has small or negligible impedance, in other words a voltage source inverter has stiff dc voltage source at its input terminals and constant output voltage at its output. Current source inverter is fed with adjustable current from a dc source of high impedance, i.e. from a stiff dc current source. In a CSI fed with stiff current source, output current wave forms are not affected by load. In voltage source inverters, the input voltage is maintained constant and the output voltage does not depend on the load. However, the waveform of load current as well as magnitude depends upon the nature of the load impedance. In CSI the magnitude of output voltage and its waveform is dependent upon the nature of

4.2 BLOCK DIAGRAM OF UPS INVERTER WITH PI CONTROLLER

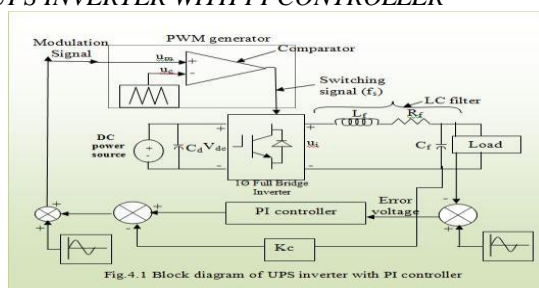

Fig 4.1: Block Diagram of UPS with PI Controller

The block diagram of UPS inverter with PI controller is shown in figure 4.1 UPS inverter typically consists of a DC power source, a full bridge PWM inverter and an LC filter. The full bridge inverter chops the DC input to a series of PWM pulses according to the modulating signal u_m . The function of the second order filter is to remove the higher frequency components of the chopped voltage u_i , R_f represents the resistance of the filter inductance.

4.3 CLOSED LOOP CONTROL OF UPS INVERTER WITH PI CONTROLLER

In modeling of UPS inverter is used to obtain the transfer function, so that the PI controller parameter values can be easily tuned for a give step input to yield better stability conditions. Because the switching frequency (20 kHz) is usually several orders higher than the fundamental frequency of the AC output, the dynamics of the PWM inverter can be ignored such that the PWM inverter is modeled as a proportional block with a gain K equal to V_{dc}/V_c .

V_{dc} is the voltage of DC source and V_c is the peak voltage of triangular carrier waveform.

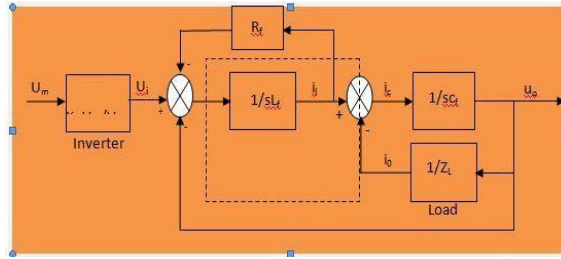

Fig.4.2 Linear model of UPS inverter

4.4 CONCLUSION

The design and implementation of closed loop control of PI based UPS inverter is described. PI controller was implemented in outer voltage loop to reduce the steady state error. Because the PI controller is designed from a linear system theory, the closed loop control of inverter for nonlinear loads will have the distortions in output voltage.

V. NEURAL NETWORK CONTROL OF UPS INVERTER

5.1 INTRODUCTION

The neural network is an interconnection of artificial neurons. Artificial neural network is a nonlinear network, and has better robustness than linear system, improves the system performance for both the linear and nonlinear type of loads. The many capabilities of neural networks, such as nonlinear functional approximation, learning, generalization, etc are in fact performed due to the nonlinear activation functions of each neuron.

5.2 ARTIFICIAL NEURON

Neural networks are simplified models of the biological nervous systems and therefore have drawn motivation from the kind of computing performed by a brain. An artificial neural network is highly interconnected network of larger number of processing elements called neurons. The basic neuron structure is as shown in figure 5.1

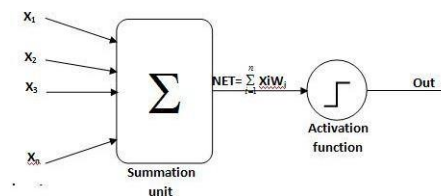

Fig.5.1 Simple model of artificial neuron

Three basic elements of the neuron model are:

- 1) A set of connecting links which fetch the input signals to the summation unit. Each of this connecting links is characterized by a weight or strength of its own. The weight of neuron may lie in the range that includes negative as well as positive values.
- 2) A summation unit or adder, for summing the input signals, weighted by the respective strength of neuron.
- 3) The last is an activation function for limiting the amplitude of the output of a neuron. The activation function is also referred as squashing function.

As shown in the figure 5.1, it consists of an input vector, is given by $[X_i]$,

$[X_i]=[x_1,x_2,x_3,\dots\dots\dots x_n]$, the number inputs applied to a neuron, the Weights associated with these inputs are represented by a weight vector $[W_i]$.

Weight vector, is given by $[W_i]= [w_1,w_2,w_3,\dots\dots\dots w_n]$.

The summation block, correspondingly the biological cell body, adds all the weighted inputs algebraically producing an output called as NET. This may be compactly stated in vector notation as follows

$$NET = \sum_{i=1}^n X_i W_i$$

5.3 ARTIFICIAL NEURAL NETWORK

A neural network is a massively distributed processor made up of single processing units, which has a natural propensity for storing experimental knowledge and making it available for use. An artificial neural network is an information processing system that has certain performance characteristics, developed as generalizations of mathematical models of human cognition or neural biology, based on assumption that,

Information processing occurs at many simple elements called neurons. Signals are passed between neurons over connection links. Each connection link has an associated weight, which in a typical neural net multiplies the signal transmitted. Each neuron applies an activation function to its net inputs to determine output.

5.4 CONCLUSION

The design, implementation and testing of closed loop control of neural network based UPS inverter is described. The training of neural network is carried out with the help of MATLAB NNtoolbox. The closed loop control of neural network based UPS Inverter enhanced the wave shape of inverter output voltage, and hence reduced the total harmonic distortion of output compared with the PI controller.

VI. PROPOSED DESIGN AND EXPECTED RESULT

The design and implementation of UPS inverter system with conventional PI controller and artificial neural network controller are developed using Matlab/Simulink toolbox. The open loop and closed loop simulation results of the UPS inverter system with conventional PI controller and artificial neural network controller are obtained. From the simulation results it is observed that the artificial neural network controller based UPS inverter system gives better performance compared to the conventional PI controller based UPS inverter system. The THD for neural network controller is less compared to PIcontroller.

The uninterruptible power supplies are emergency power sources for applications where a power failure for a small amount of time causes large disturbances. The neural network control of UPS inverters is capable of producing low total harmonic distortion. Since a PI controller is designed from linear system theory, the output voltage of UPS inverter with PI controller will get distortion for nonlinear loads. The neural network had an advantage of adaptability to all types of loads, reduces the total harmonic distortion of output voltage, and hence used for the control of output voltage in UPS inverter applications. The design, implementation and testing of closed loop control of PI based UPS inverter and an artificial neural network based UPS inverter has been carried out. With the help of Matlab/Simulink toolbox.

REFERENCES

- [1]. P.D.Ziogas, "Optimum voltage and harmonic control PWM techniques for three-phase static UPS inverters," IEEE Trans. Ind. Appl. vol. IA-16, no. 14, pp. 542-546, July/Aug 1980.
- [2]. N.M.Abdel-Rahim and J.E.Quaicoe, "Analysis and design of a multiple feedback loop control strategy for single phase voltage source UPS inverters," IEEE Trans. Power Electron. vol. 11, pp. 532-541, July 1996.
- [3]. M.J.Ryan, W.E.Brumsickle, and R.D.Lorenz, "Control topology options for single phase UPS inverter," IEEE Trans. Ind. Appl. vol. 33, pp. 493-501, Mar/Apr. 1997.
- [4]. B.K.Bose, "Expert systems, fuzzy logic, and neural network applications in power electronics and motion control," Proc. IEEE, vol. 82, pp. 1083-1112, 1992.
- [5]. D.Daniolos, M.K.Darwish, and P.Mehta, "Optimized PWM inverter control using artificial neural networks," Electron Lett., vol. 31, no. 20, pp. 1739-1740, 1995.
- [6]. B.R.Lin and R.G.Hoft, "Power electronics inverter control with neural networks," in Proc. IEEE-APEC, 1993, pp. 128-134.
- [7]. "Introduction to neural networks using matlab 6.0" - S.N Sivanandam, S Sumathi, S.N Deepa, Tata mcgrahill publishers.
- [8]. Mohammad H.Rashid, "Power Electronics Circuits Devices and Applications," 2nd Edn. Prentice Hall
- [9]. "Using MATLAB," The mathworks, Inc.
- [10]. L. A. Zadeh, "Fuzzy sets, Informat. Contr., vol. 8, pp.
- [11]. "Outline of a new approach to the analysis of systems and decision processes," IEEE Trans. Syst., Man, Cybern., vol. SMC-3, no. 1, pp. 28-44, 1973 [12]. D. H. Nguyen and B. Widrow, "Neural networks for self-learning control systems," IEEE Contr. Syst. Mag., vol. 10, pp. 18-23, Apr. 1990.
- [13]. K. A. Krishnamoorthy, G. K. Dubey, G. N. Revankar, "Converter Control with Selective Reduction of Harmonics", Proc. IEE, vol. 125, No. 2, 1978, pp 141-145.
- [14]. S. S. Ambekar, A. G. Keskar, "A Neuro-Evolutionary Approach to Selective Harmonic Elimination for a Single Phase Converter / Inverter", International Conference on Evolutionary Computing, Computer, Communication, Control & Power, Chennai, Jan. 2000.
- [15]. A Text Book on "Elements of Artificial Neural Networks", K. Mehrotra, C. K. Mohan, S. Ranka, Penram International Publishing, India.
- [16]. Joy Mazumdar, R.G. Harley, F.C. Lambart, G.K. Venayagamoorthy, "Neural Network based Method for Predicting Non-linear Load Harmonics", IEEE Trans. On Power Electronics, vol. 22, No. 3, May 2007, pp 1036-1045.
- [17]. S. Joseph Jawhar, N.S. Marinuthu, "An Intelligent Controller for a non-linear Power Electronic Boost Converter", International Journal of Soft Computing 3 (1) : 69-73, 2008.
- [18]. John W. Finch, Damian Giaouris, "Controlled AC Electric Drives", IEEE Trans. On Industrial Electronics, vol. 55, No. 2, Feb. 2008, pp 481-491.